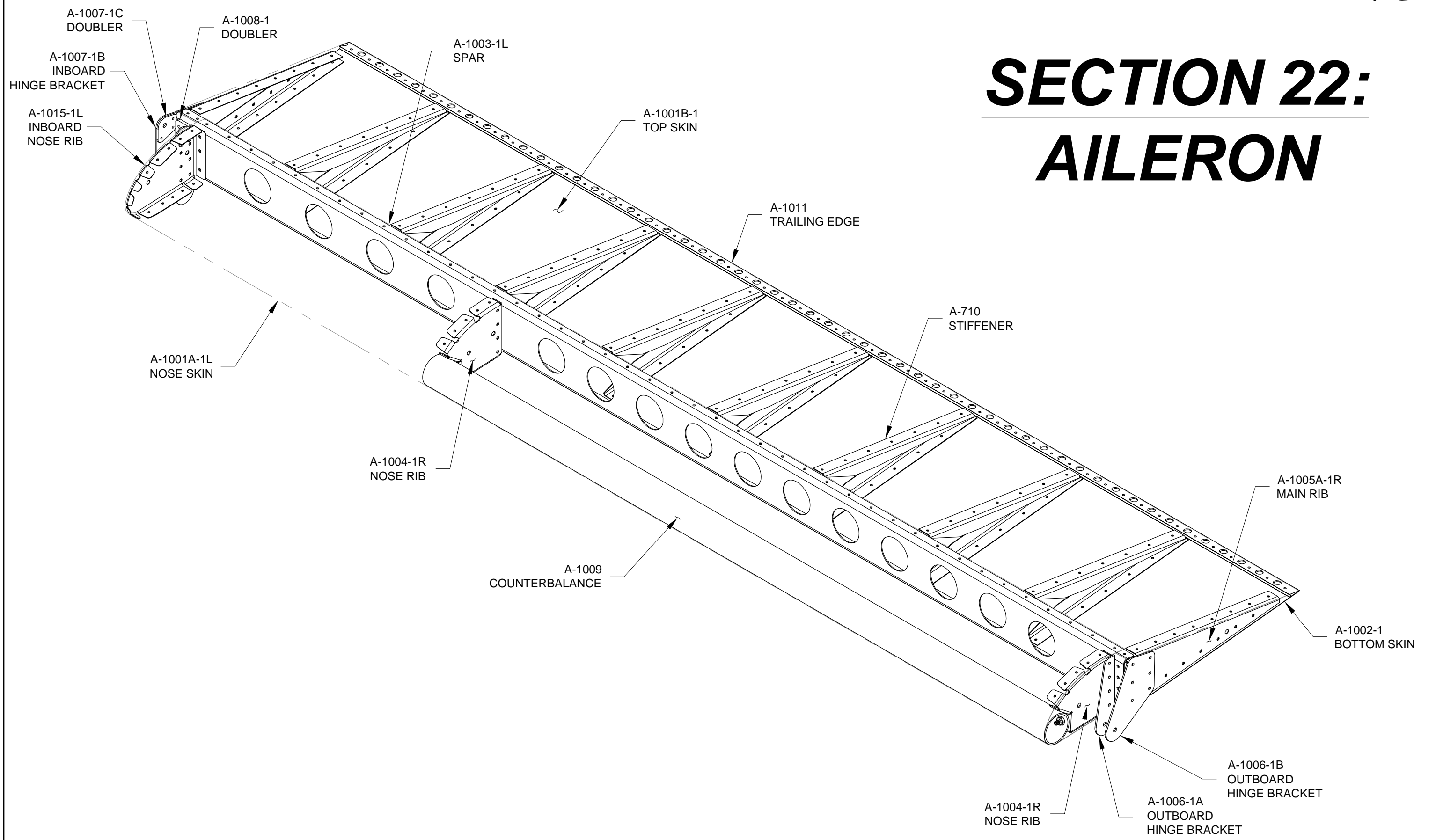


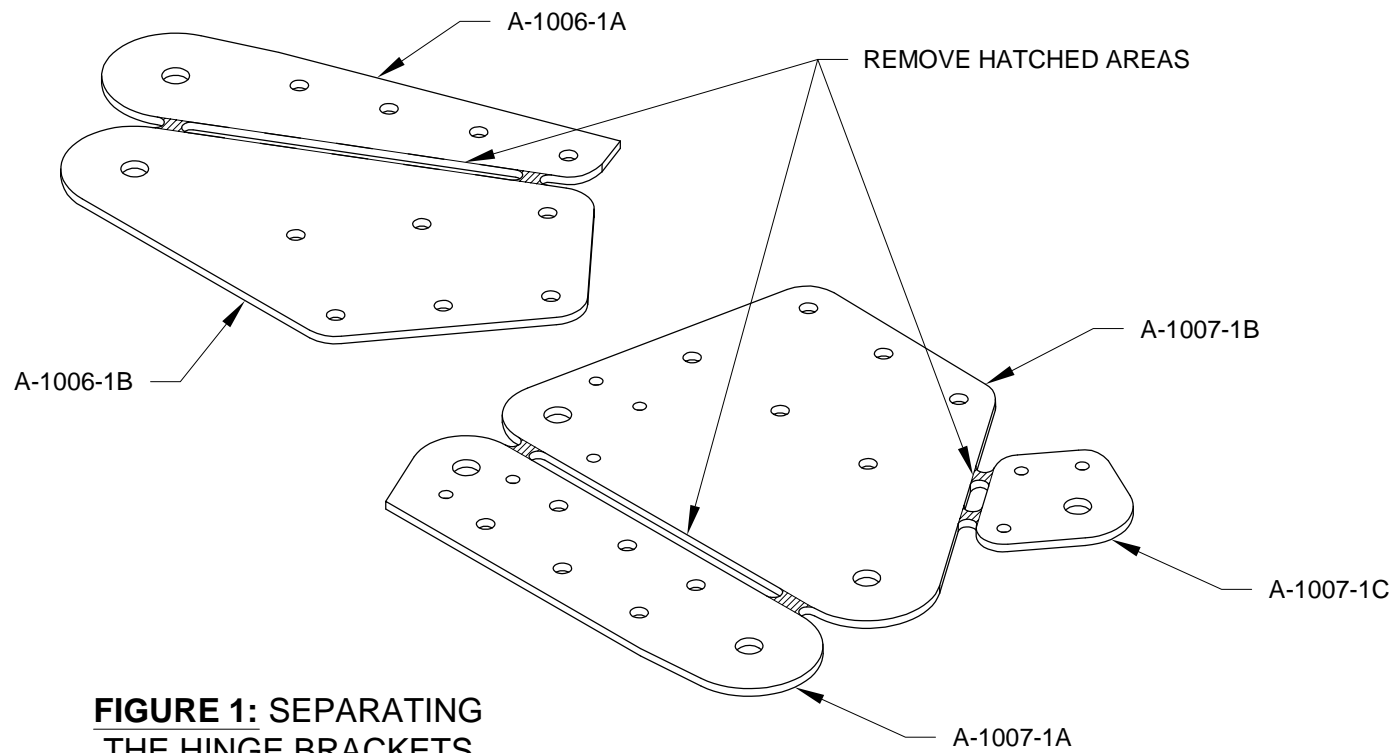
# SECTION 22: AILERON



DATE OF COMPLETION:	_____		
PARTICIPANTS:	_____		
DATE: 04/15/13	REVISION: 0	RV-14	PAGE 22-01



**Step 1:** Separate the A-1006-1 Outboard Hinge Brackets into parts A and B. Separate A-1007-1 Inboard Hinge Brackets into parts A, B, and C. See Figure 1.



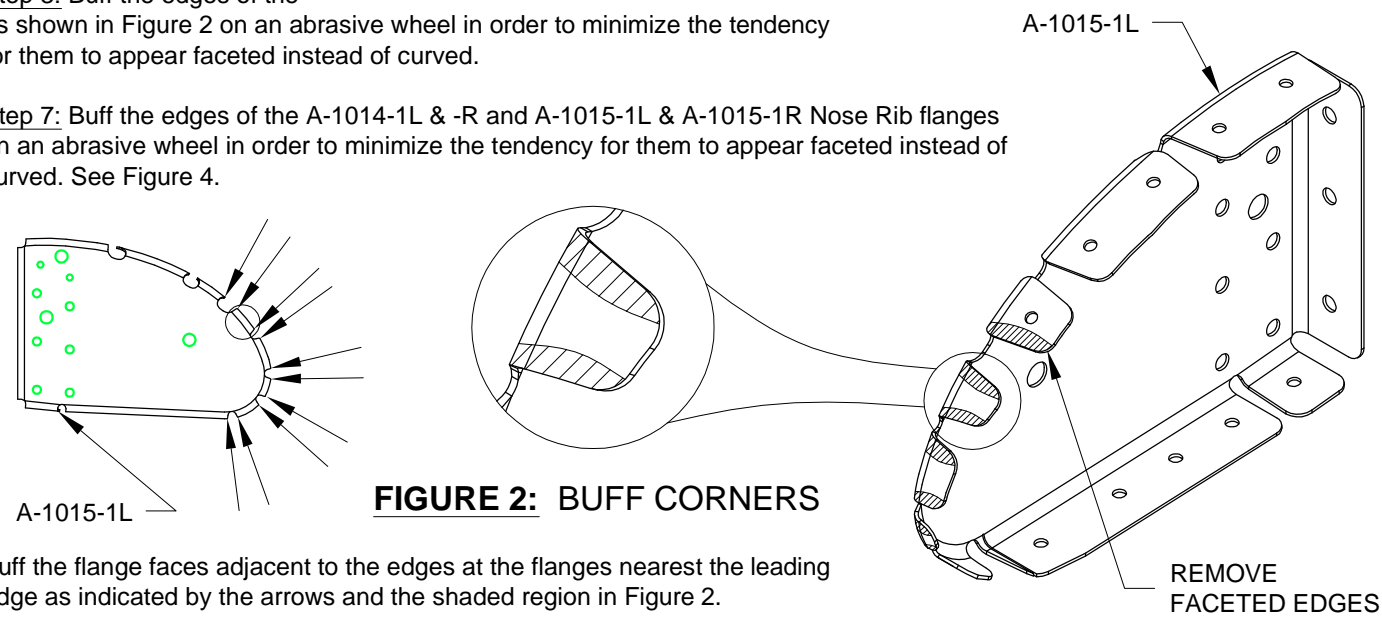
**FIGURE 1: SEPARATING THE HINGE BRACKETS**

**Step 2:** Flute and straighten as required to adjust the flanges of the A-1004-1L and A-1004-1R Nose Ribs and A-1015-1L and A-1015-1R Inboard Nose Ribs to 90°.

Final-Drill #40, deburr and dimple all the holes in the flanges of the nose ribs and inboard nose ribs.

**Step 3:** Buff the edges of the as shown in Figure 2 on an abrasive wheel in order to minimize the tendency for them to appear faceted instead of curved.

**Step 7:** Buff the edges of the A-1014-1L & -R and A-1015-1L & A-1015-1R Nose Rib flanges on an abrasive wheel in order to minimize the tendency for them to appear faceted instead of curved. See Figure 4.



**FIGURE 2: BUFF CORNERS**

Buff the flange faces adjacent to the edges at the flanges nearest the leading edge as indicated by the arrows and the shaded region in Figure 2.

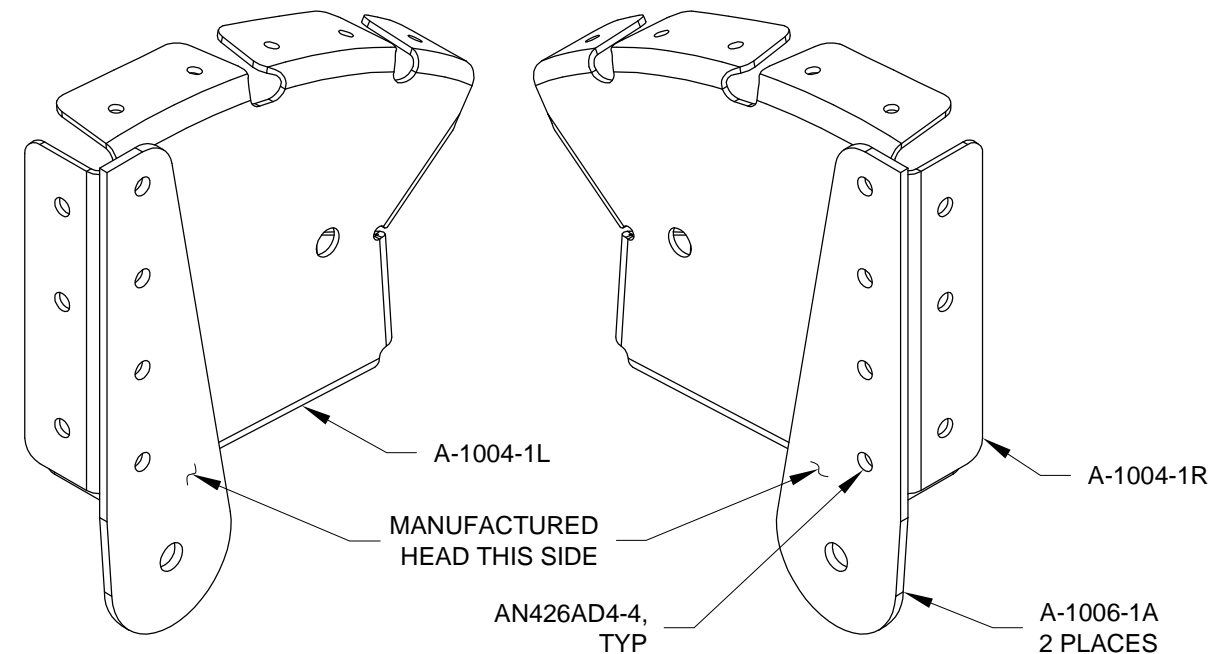
**Step 4:** Final-Drill #30 the .129 [3.3 mm] holes common to the A-1006-1A Outboard Hinge Brackets and the A-1004-1R and A-1004-1L Nose Ribs. Machine countersink the outboard hinge brackets for the head of a AN426AD4 rivet as shown in Figure 3. Deburr the outboard hinge brackets and the A-1004-1R and A-1004-1L Nose Ribs.

**Step 5:** Final-Drill #30 the .129 [3.3 mm] holes common to the A-1007-1A Inboard Hinge Brackets and the A-1015-1L and A-1015-1R Ribs. Machine countersink the inboard hinge bracket for the head of an AN426AD4 Rivet and deburr. See Figure 4.

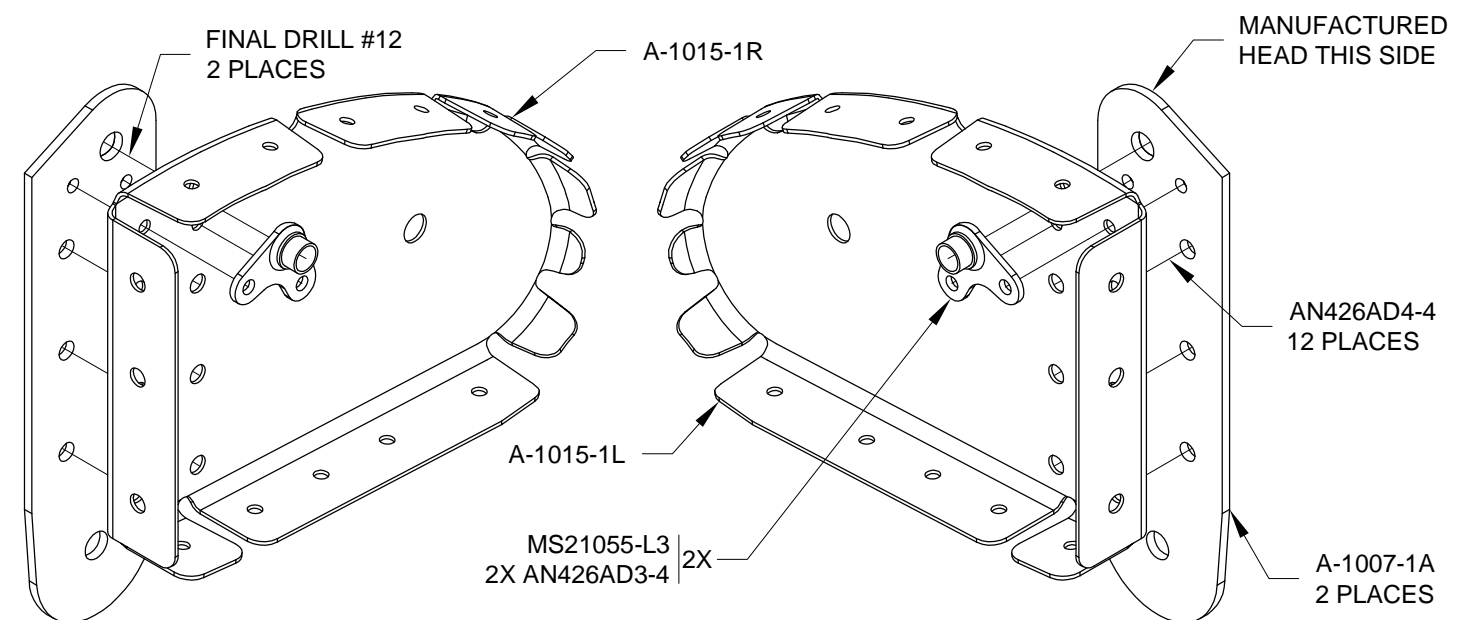
Final-Drill #12 the .188 [4.8 mm] bolt holes in the inboard hinge brackets, ribs and the A-1007-1A Inboard Hinge Brackets.

**Step 6:** Rivet the A-1006-1A Outboard Hinge Brackets to the A-1004-1R and A-1004-1L Nose Ribs as shown in Figure 3.

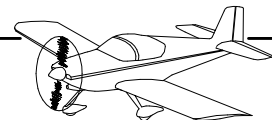
**Step 7:** Rivet the A-1007-1A Inboard Hinge Brackets to the A-1015-1L and A-1015-1R Ribs with the rivets as shown in Figure 4. Install the nutplates as shown in Figure 4.



**FIGURE 3: OUTBOARD HINGE BRACKET TO NOSE RIB INSTALLATION**



**FIGURE 4: INBOARD HINGE BRACKET TO NOSE RIB INSTALLATION**



Step 1: Separate the A-1005-1L Main Ribs into A-1005-1A-L and A-1005-1B-L.

Separate the A-1005-1R Main Ribs into A-1005-1A-R and A-1005-1B-R. See Figure 1.

Dimple the .098 [2.5 mm] holes in the main ribs.

Step 2: Deburr the A-1005-1A-L and A-1005-1A-R Main Ribs and the A-1005-1B-L and A-1005-1B-R Main Ribs.

Deburr the A-1006-1B Outboard Hinge Brackets, A-1007-1B and A-1007-1C Inboard Hinge Brackets.

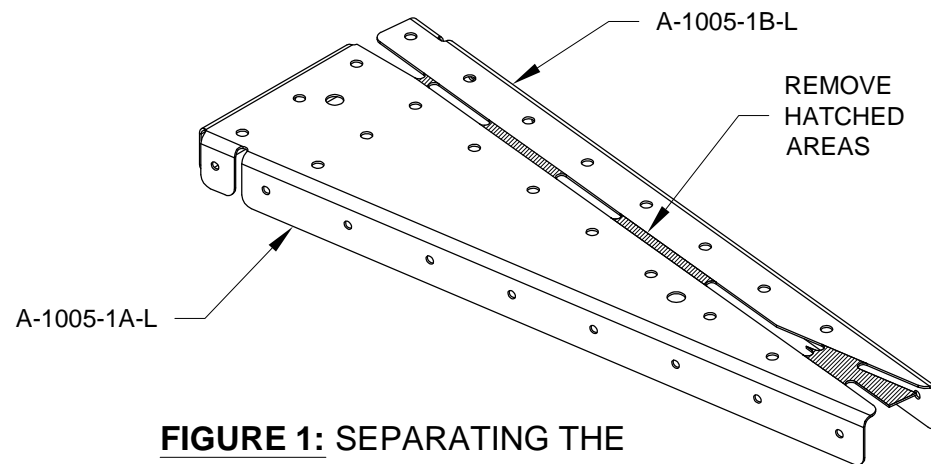
Step 3: Machine countersink the .129 [3.3 mm] holes in the A-1006-1B Outboard Hinge Brackets and A-1007-1B Inboard Hinge Brackets to fit the head of an AN426AD4 rivet. See Figures 2, 4, and 5.

Parts for the right aileron must be countersunk on the side opposite that shown in Figures 2, 4, and 5.

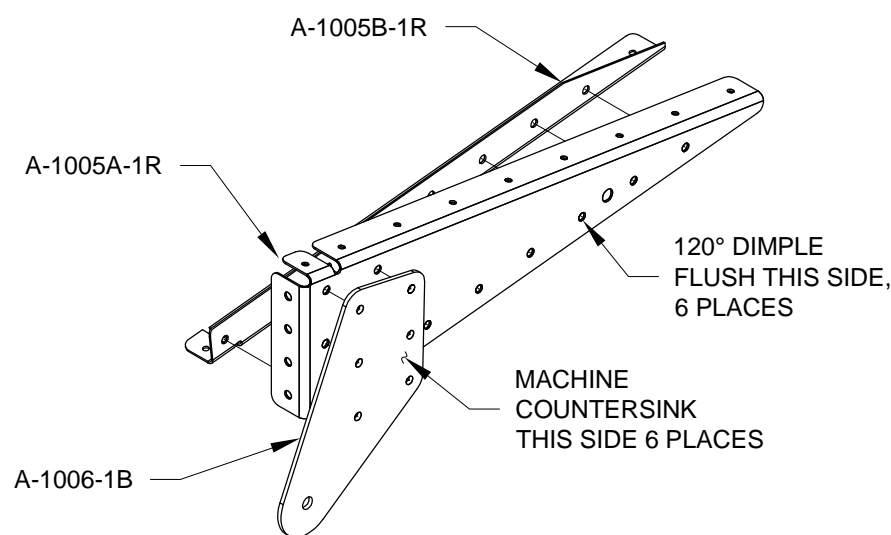
Step 4: Cleco the A-1007-1B and A-1007-1C Inboard Hinge Brackets to each other. Final-Drill #12 the .188 [4.8 mm] hole and machine countersink for the head of an AN509-10 countersunk screw. See Figure 2.

Machine countersink the .098 [2.5 mm] holes in the A-1007-1B Inboard Hinge Bracket to fit the head of an AN426AD3 rivet as shown in Figures 2 and 4.

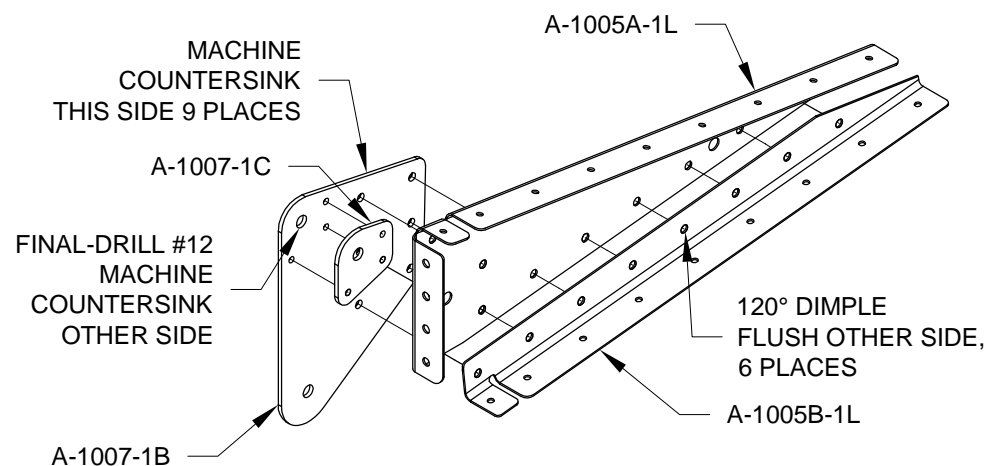
Parts for the right aileron must be countersunk on the side opposite that shown in Figures 2 and 4.



**FIGURE 1: SEPARATING THE MAIN RIBS (LEFT SHOWN)**



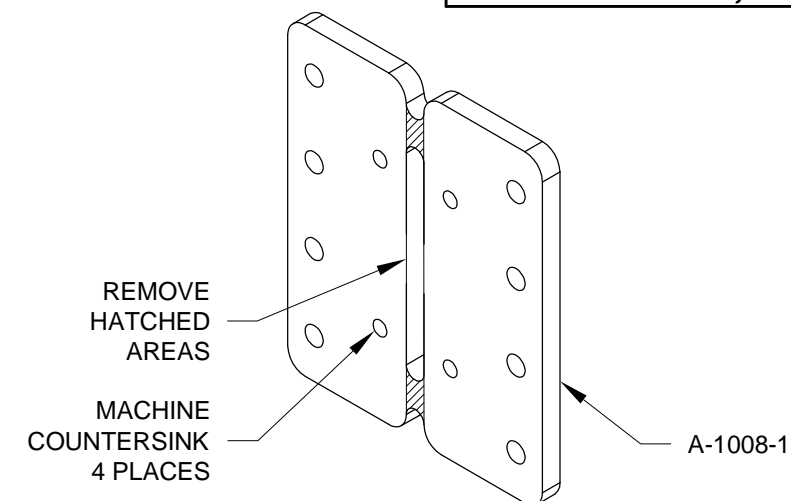
**FIGURE 2: MACHINE COUNTERSINK MAIN RIBS AND HINGE BRACKETS**



Step 5: Machine countersink the A-1008-1 Doubler for the head of AN426AD3 rivets as shown in Figure 3.

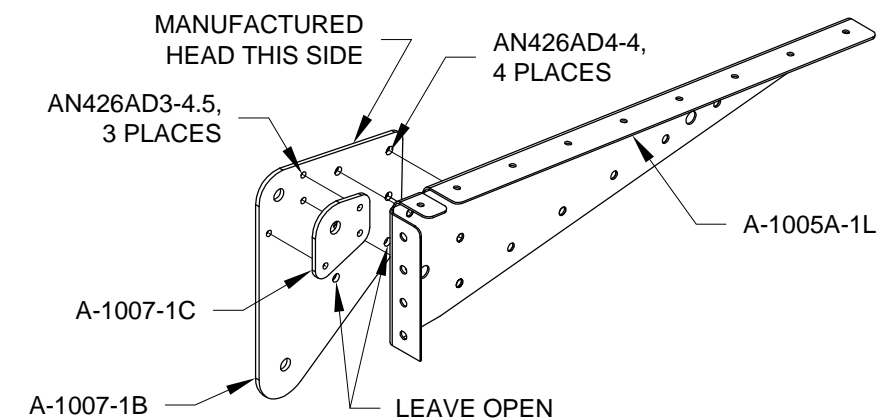
Removed the hatched areas on the doubler as shown in Figure 3 to make 2 parts.

Step 6: Prime if/as desired.



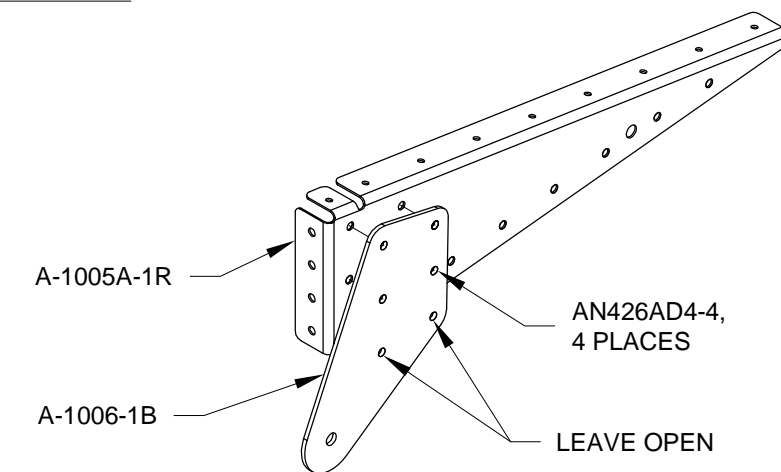
**FIGURE 3: SEPARATING THE DOUBLERS**

Step 7: Cleco then rivet the A-1007-1B and A-1007-1C Inboard Hinge Brackets to the A-1005A-1L and A-1005A-1R Main Ribs. Leave open the 2 bottom holes as noted in Figure 4.



**FIGURE 4: INBOARD HINGE BRACKET ATTACH**

Step 8: Cleco then rivet the A-1006-1B Outboard Hinge Brackets to the A-1005A-1L and A-1005A-1R Main Ribs. Leave open the 2 bottom holes as noted in Figure 5.



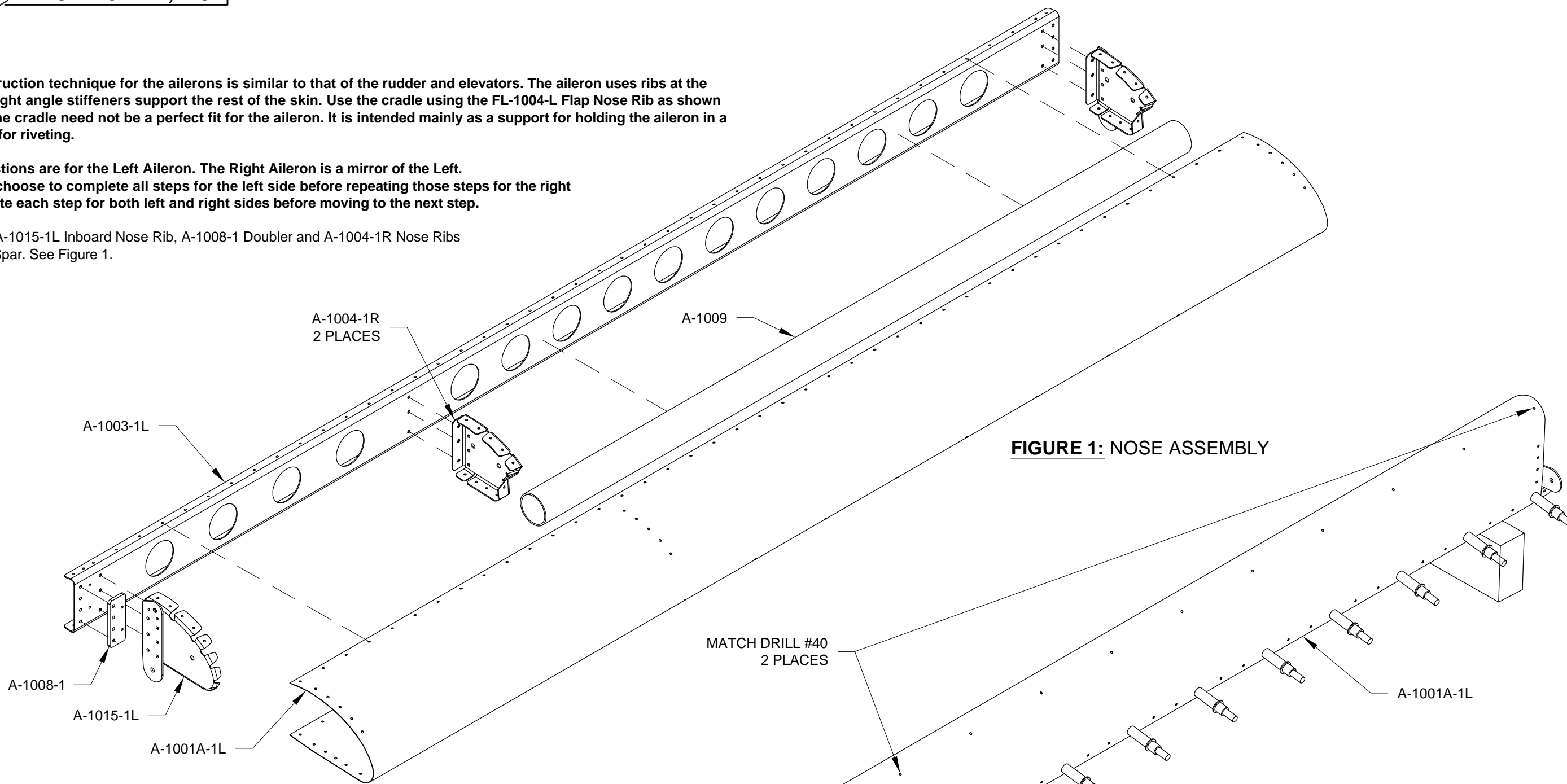
**FIGURE 5: OUTBOARD HINGE BRACKET ATTACH**



**NOTE:** The construction technique for the ailerons is similar to that of the rudder and elevators. The aileron uses ribs at the ends only while light angle stiffeners support the rest of the skin. Use the cradle using the FL-1004-L Flap Nose Rib as shown on Page 21-02. The cradle need not be a perfect fit for the aileron. It is intended mainly as a support for holding the aileron in a position suitable for riveting.

**Assembly instructions are for the Left Aileron. The Right Aileron is a mirror of the Left. The builder may choose to complete all steps for the left side before repeating those steps for the right side or to complete each step for both left and right sides before moving to the next step.**

**Step 1:** Cleco the A-1015-1L Inboard Nose Rib, A-1008-1 Doubler and A-1004-1R Nose Ribs to the A-1003-1L Spar. See Figure 1.



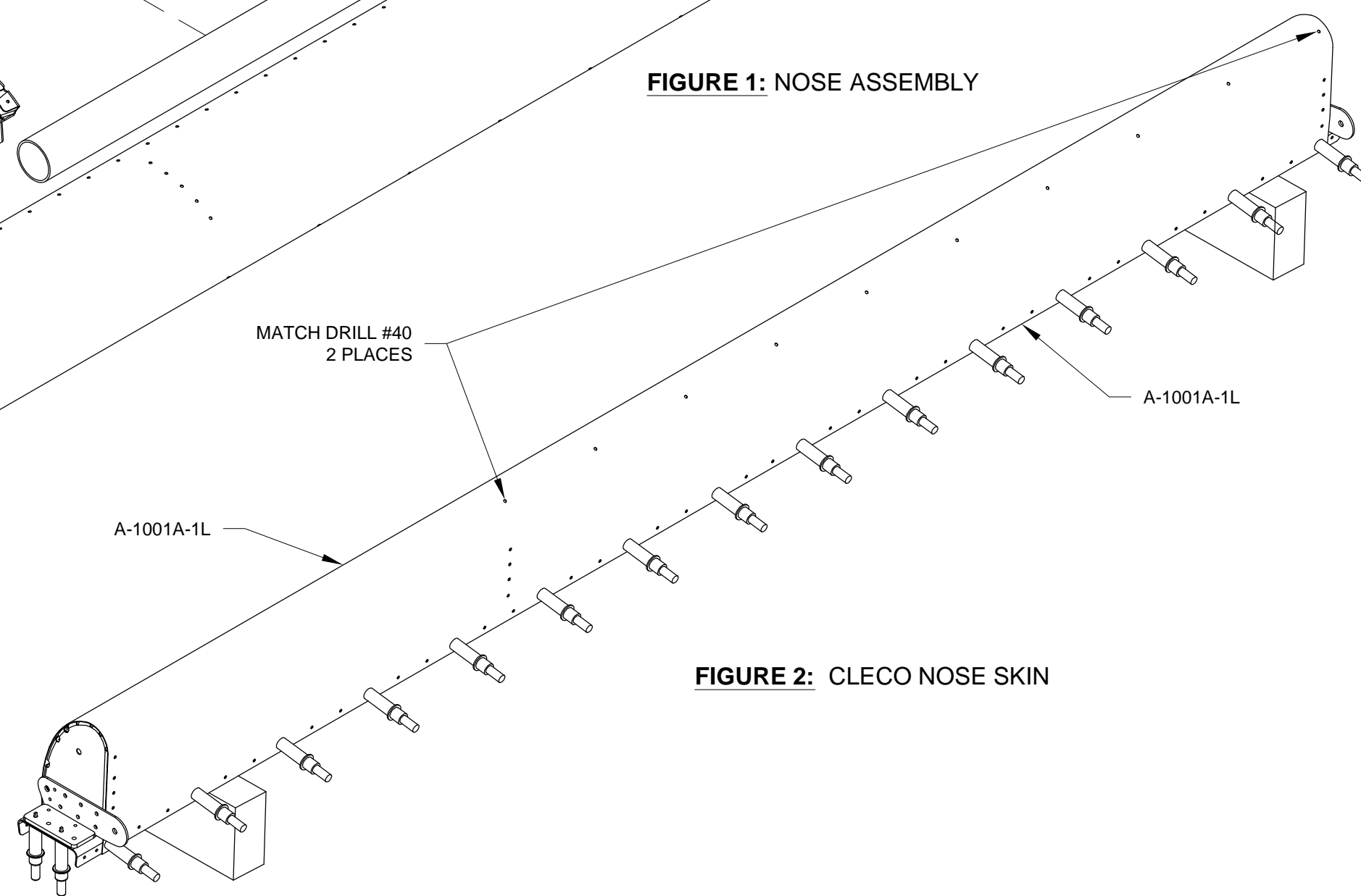
**FIGURE 1: NOSE ASSEMBLY**

**Step 2:** Cut a length of ST304-065X1.375 Steel Tube to 34.625 [879.5 mm] to make the A-1009 Counterbalance.

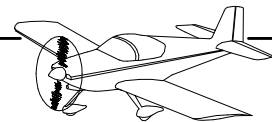
**Step 3:** Cleco the A-1001A-1L Nose Skin to the lower flange of the A-1003-1L Spar at every third hole. Lay the A-1009 Counterbalance into the nose skin so that it is flush with the outboard edge of the nose skin. Cleco the nose skin to the top flange of the spar at every third hole applying downward pressure on the nose skin if/as required to insert the clecos. Cleco the nose skin to the A-1004-1R Nose Ribs and to the A-1015-1L Inboard Nose Rib as shown in Figure 1. Place the assembly leading edge up onto a narrow table or blocks as shown in Figure 2.

**Step 4:** Match-Drill #40 the A-1001A-1L Nose Skin into the A-1009 Aileron Counterbalance as shown in Figure 2.

Remove the A-1003-1L Spar.

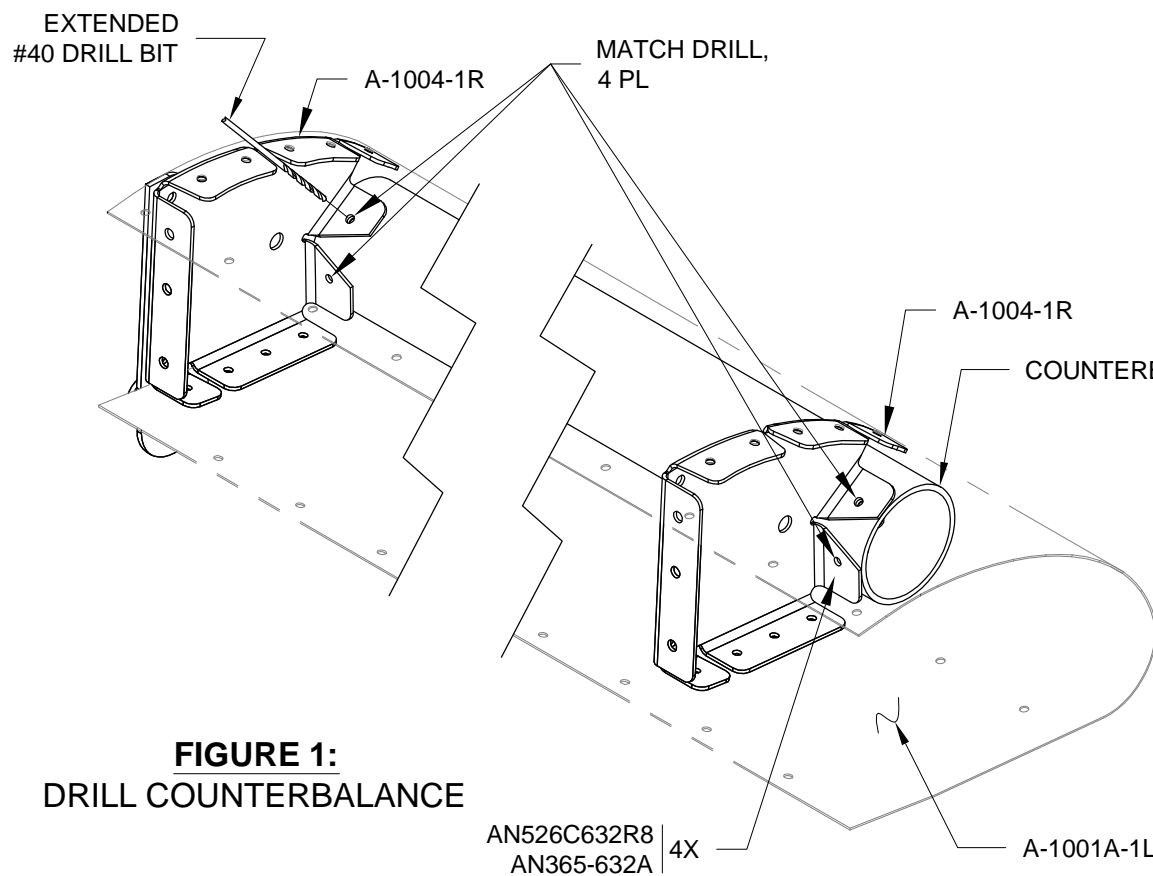


**FIGURE 2: CLECO NOSE SKIN**



**Step 1:** Match Drill #40 the holes in the lower tab of the A-10004-1R Nose Ribs into the A-1009 Counterbalance as shown in Figure 1.

Cleco the A-1009 Counterbalance to the A-1004-1R Nose Ribs. Remove the A-1001A-1L Nose Skin.



**FIGURE 1:**  
DRILL COUNTERBALANCE

**Step 2:** Use an extended #40 drill bit to mark the A-1009 Counterbalance to A-1004-1R Nose Rib attach holes on the spar by leaning the drill in alongside the rib as shown in Figure 1.

Remove the counterbalance. Final-Drill #27 the marked holes and the two #40 holes in the counterbalance. Final-Drill #27 the four corresponding holes in the nose ribs.

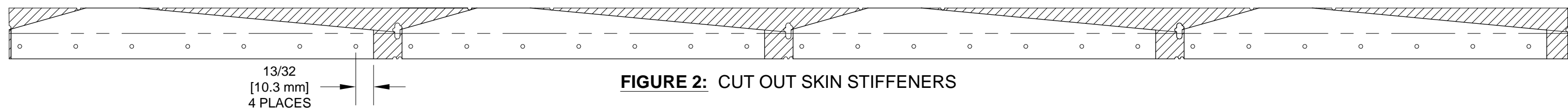
Attach the counterbalance to the nose ribs using the hardware called out in Figure 1. If you have difficulty getting a screwdriver on the head of the screw use an offset screwdriver or a Phillips bit tip held in Vise-Grip pliers at 90°.

**Step 3:** Cleco the A-1001A-1L Nose Skin and A-1003-1L Spar to the A-1004-1R Nose Ribs, A-1015-1L Inboard Nose Rib, and A-1003-1L Spar. Match-Drill #40 into the counterbalance along its length using the holes in the leading edge of the nose skin as drill guides. Start drilling at one end. Insert a cleco after each hole is drilled to prevent the counterbalance from being pushed away from the skin. Final-drill #30 these holes. See Page 22-04, Figure 2 for hole locations.

**Step 4:** Remove the A-1001A-1L Nose Skin.

Remove the A-1004-1R Nose Ribs and A-1015-1L Inboard Nose Rib from the spar.

**Step 5:** Final-Drill #40 all the .094 [2.4 mm] holes in the A-710 Stiffeners. Cut the stiffeners from the angle strip provided and trim as shown in Figure 2. The angle strip is shown unbent for clarity.



**FIGURE 2:** CUT OUT SKIN STIFFENERS

**CAUTION:** Be careful to dimple the skins in the correct direction.

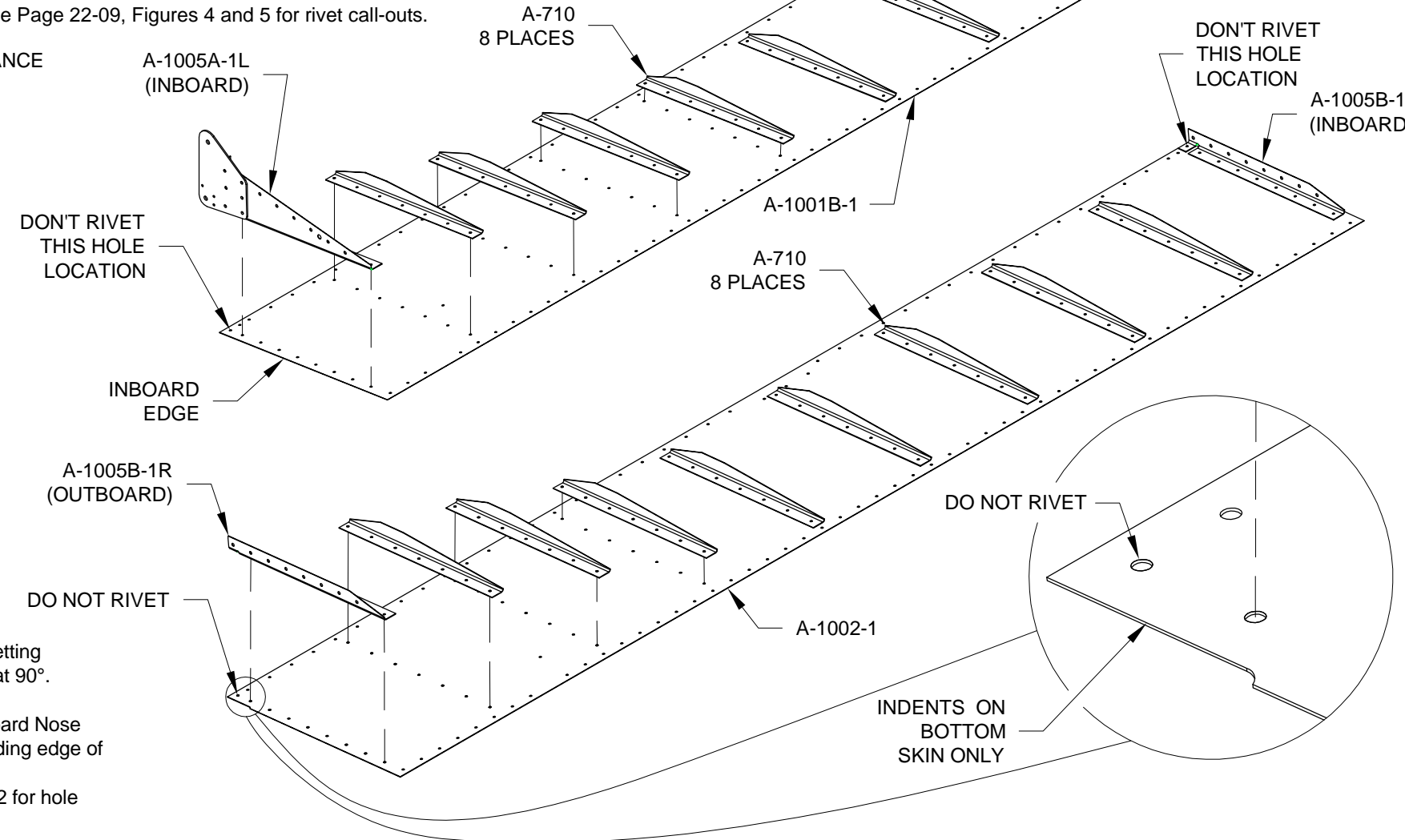
**NOTE:** If electing to prime, leave the skins unprimed in the area where they will contact the A-1011 Trailing Edge because adhesive will be applied.

**Step 6:** Deburr and dimple the holes common to the A-710 Stiffeners, the A-1005A-1L, A-1005A-1R, A-1005B-1L and A-1005B-1R Main Ribs and the A-1001B-1 Top Skins and A-1002-1 Bottom Skins as shown in Figure 3.

**Step 7:** Prime the the A-1001B-1 Top Skins, A-1002-1 Bottom Skins, and A-710 Stiffeners.

**Step 8:** Rivet the A-710 Stiffeners, the A-1005A-1L and A-1005A-1R Main Ribs, and the A-1005B-1L and A-1005B-1R Main Ribs to the A-1001B-1 Top Skin and A-1002-1 Bottom Skin using the back-riveting method described in Section 5.6.

See Page 22-09, Figures 4 and 5 for rivet call-outs.



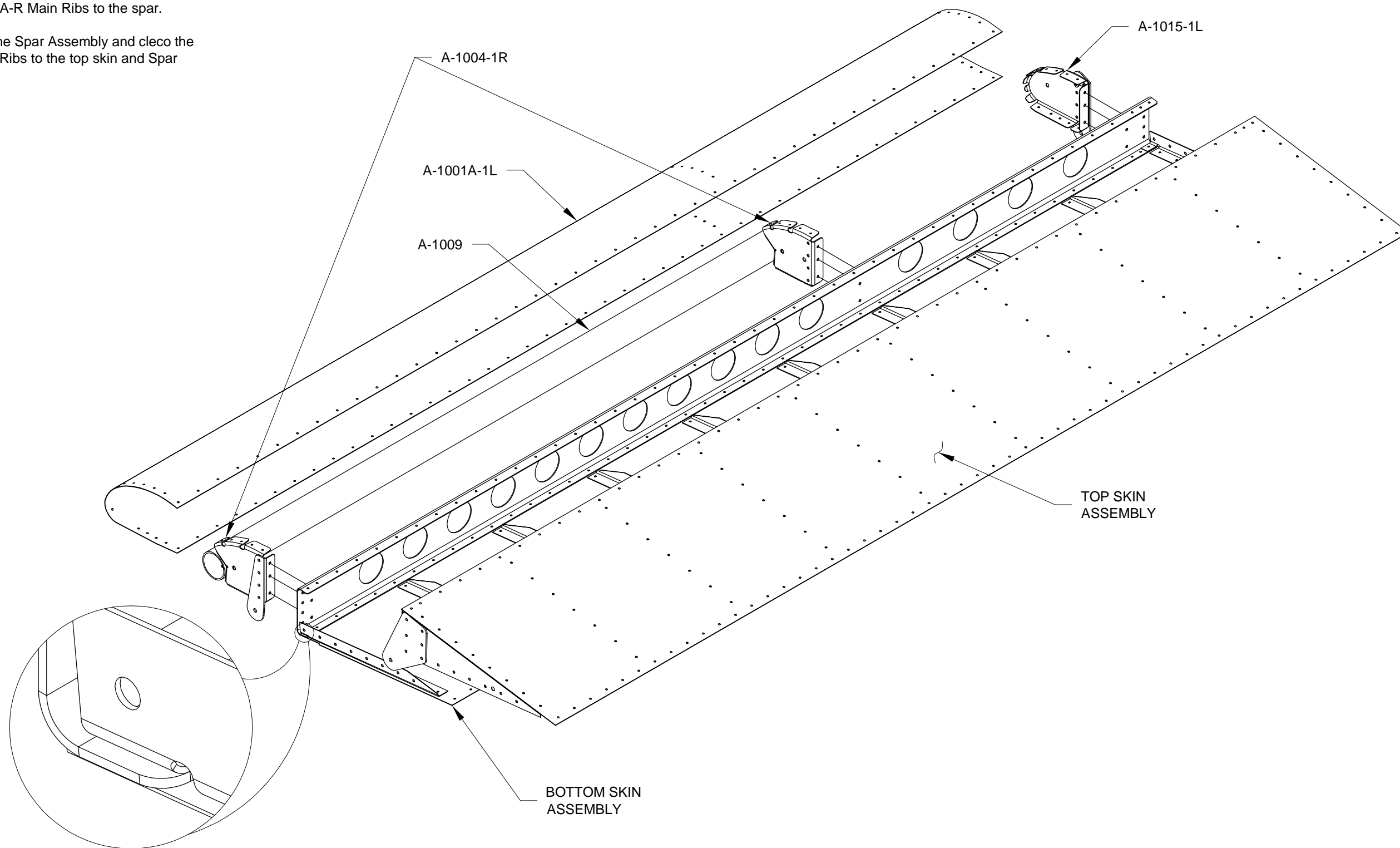
**FIGURE 3:** ATTACHING STIFFENERS AND MAIN RIBS TO SKINS



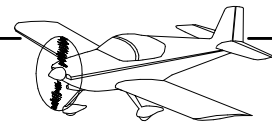
Step 1: Cleco the Top Skin Assembly and the A-1001A-1L Nose Skin to the top flange of the A-1003-1L Spar at every other hole. Cleco the nose skin to the A-1004-1R Nose Ribs, and A-1015-1L Inboard Nose Rib.

Cleco the A-1005-1A-L and A-1005-1A-R Main Ribs to the spar.

Cleco the Bottom Skin Assembly to the Spar Assembly and cleco the A-1005-1B-L and A-1005-1B-R Main Ribs to the top skin and Spar Assembly.

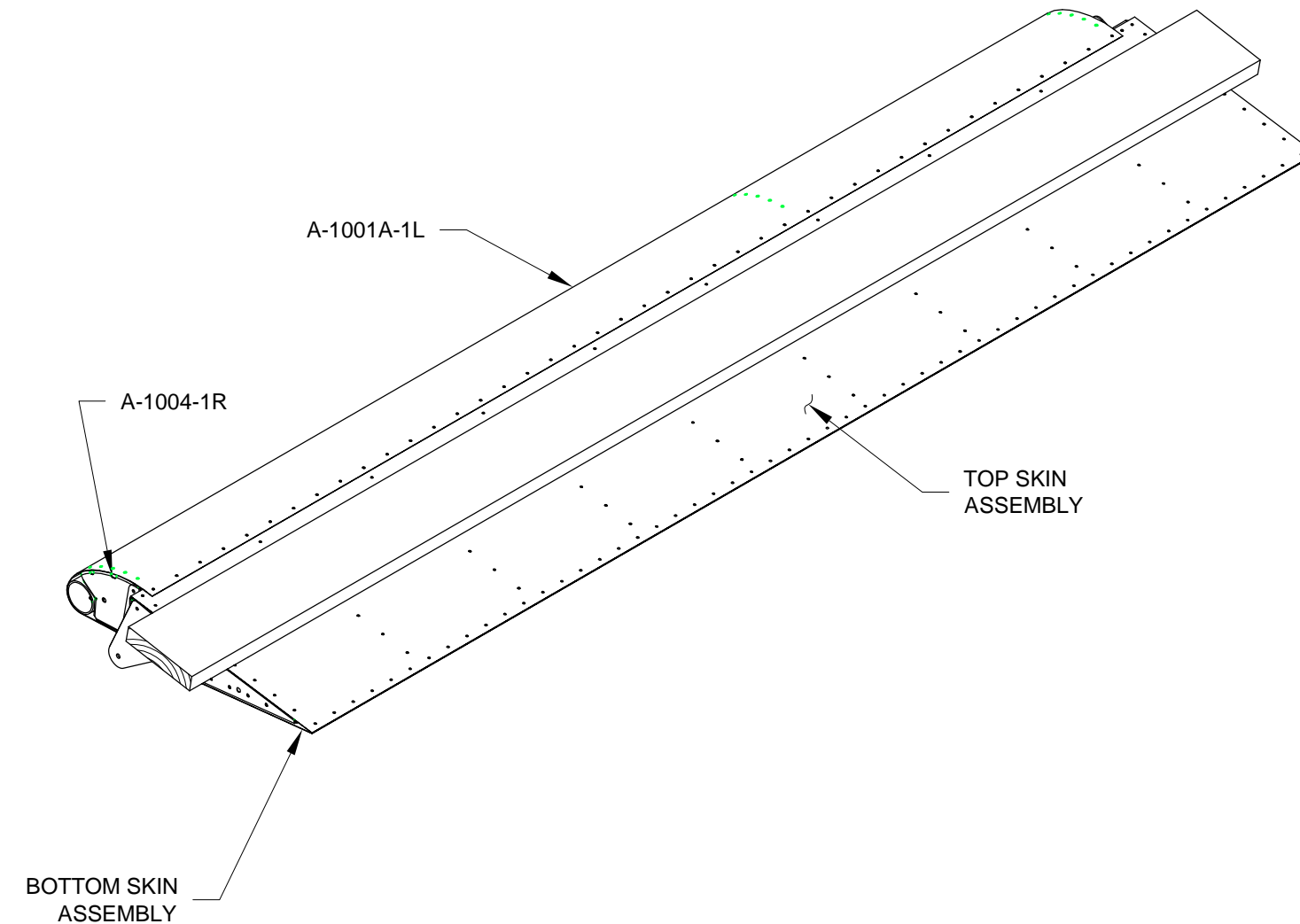


**FIGURE 1: FITTING ASSEMBLY**



**Step 1:** Lay the assembly flat on the table top hanging the clecos which are holding the A-1001A-1L Nose Skin to the A-1002-1 Bottom Skin and A-1003-1L Spar over the edge. Use a straight board to distribute weight over the main ribs to keep the skin firmly against the table with no twist. See Figure 1.

**Step 2:** Check the A-1001A-1 Nose Skin for bowing with a straight edge held spanwise midway between the the leading edge and spar. About 1/16 [1.6 mm] of rise is acceptable. If necessary, squeeze the skin down by hand to minimize the bow.

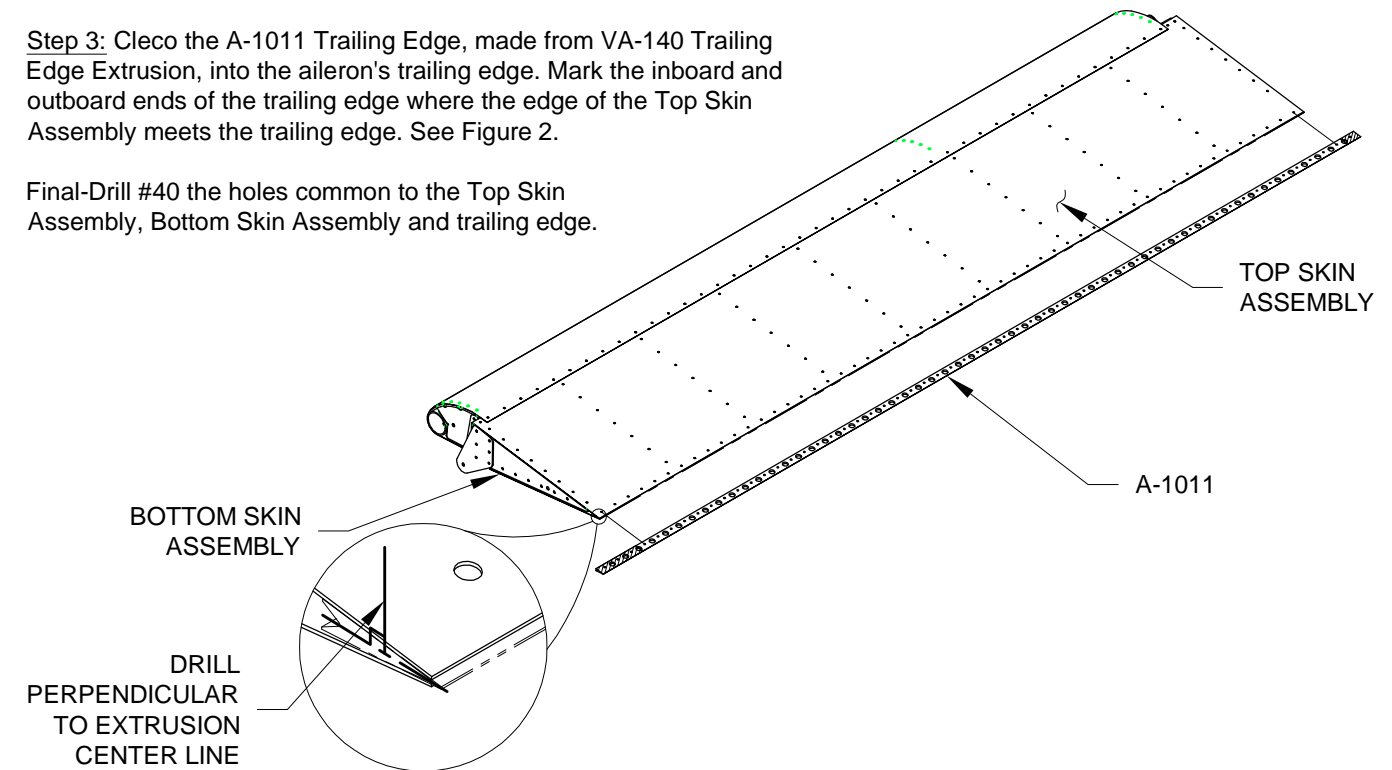


**FIGURE 1: FINAL-DRILL SPAR AND NOSE RIBS**

**NOTE:** Drill perpendicular to the centerline of the extrusion, not the surface of the top skin. The difference is only a few degrees, but using the correct reference will give better results.

**Step 3:** Cleco the A-1011 Trailing Edge, made from VA-140 Trailing Edge Extrusion, into the aileron's trailing edge. Mark the inboard and outboard ends of the trailing edge where the edge of the Top Skin Assembly meets the trailing edge. See Figure 2.

Final-Drill #40 the holes common to the Top Skin Assembly, Bottom Skin Assembly and trailing edge.



**FIGURE 2: INSERT TRAILING EDGE**

**Step 4:** Disassemble the aileron. Deburr all parts.

Trim the A-1011 Trailing Edge at the marks made on the inboard and outboard locations as marked in Step 3.

**Step 5:** Make a edge break in the aft edge of the A-1001A-1L Leading Edge, A-1001B-1 Top Skin, and A-1002-1 Bottom Skin. See Section 5.10 & 5.4.

**Step 6:** With the exception of the A-1011 Trailing Edge, dimple wherever exterior flush rivets will be installed, including the spar flanges. It is normal for the spar to bow slightly when dimpled.

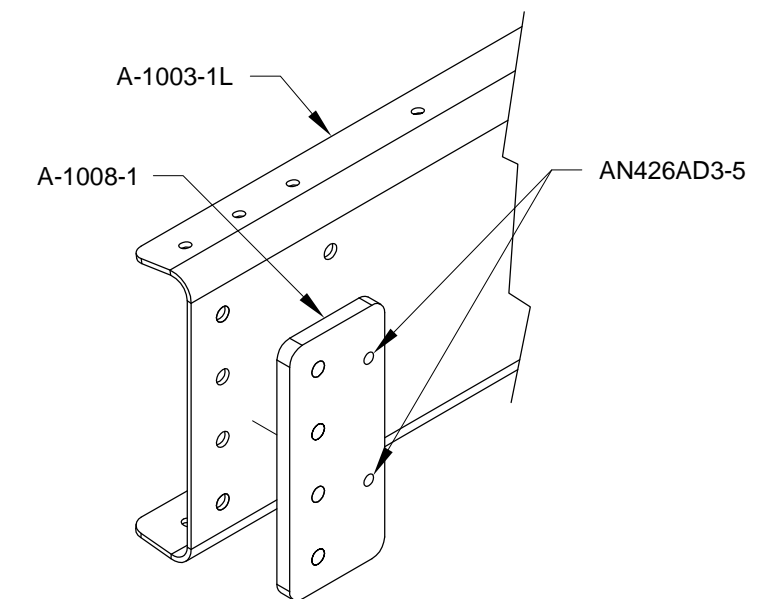
Machine countersink the holes in the trailing edge with the tool perpendicular to the surface of the part.

Dimple all remaining holes in the skins.

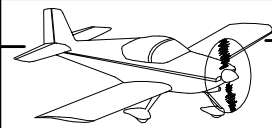
If priming, note that the A-1009 Counterbalance is stainless steel and need not be primed.

Do not prime the A-1011 Trailing Edge.

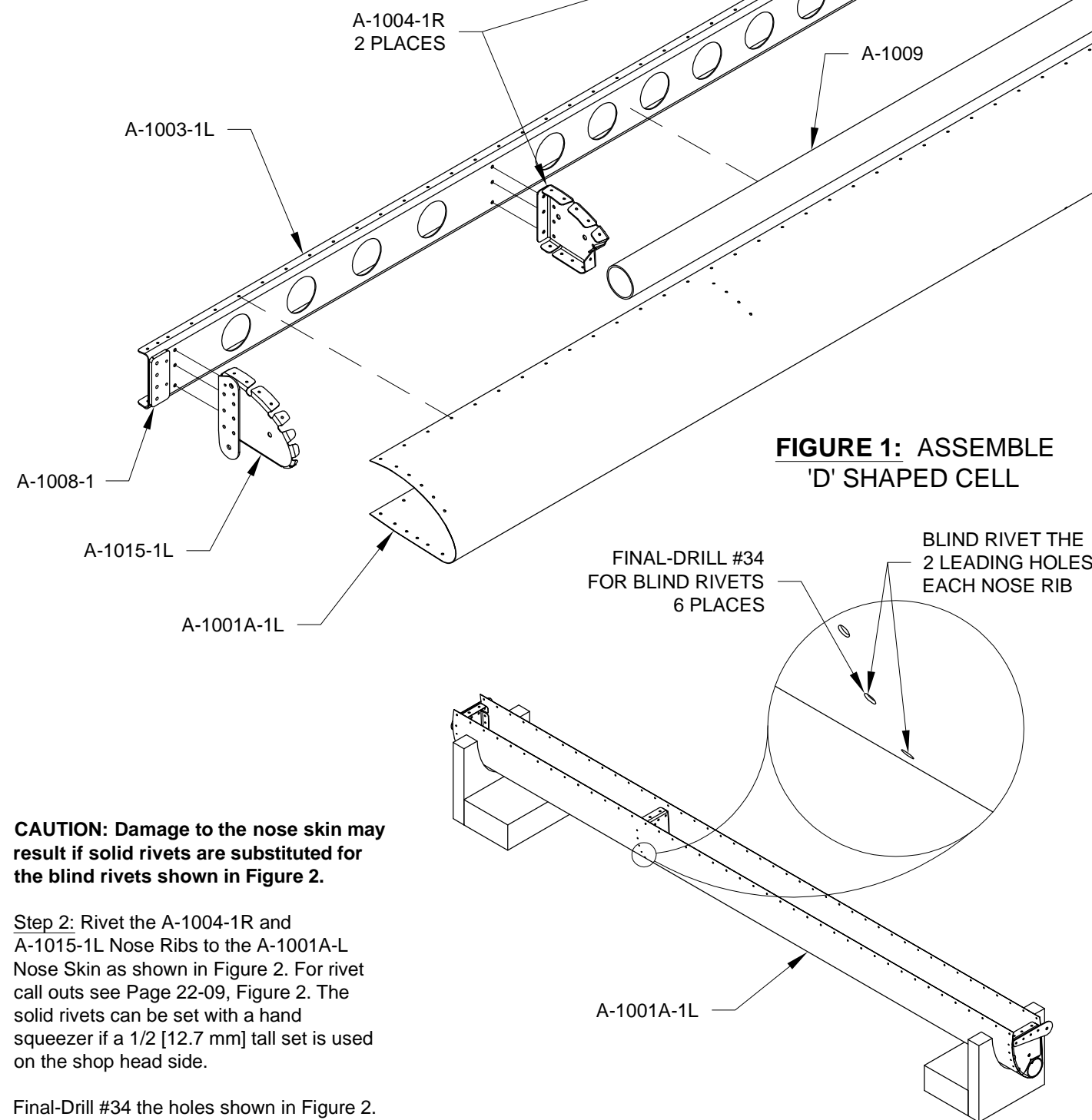
**Step 7:** Rivet the A-1008-1 Doubler to the A-1003-1L Spar using the rivets called out in Figure 3.



**FIGURE 3: ATTACHING THE DOUBLER TO THE SPAR**



**Step 1:** Cleco the Nose rib/Counterbalance Subassembly and the A-1015-1L Inboard Nose Rib into the A-1001A-1L Nose Skin by installing clecos into the counterbalance and all nose ribs.



**FIGURE 1: ASSEMBLE 'D' SHAPED CELL**

**CAUTION:** Damage to the nose skin may result if solid rivets are substituted for the blind rivets shown in Figure 2.

**Step 2:** Rivet the A-1004-1R and A-1015-1L Nose Ribs to the A-1001A-1L Nose Skin as shown in Figure 2. For rivet call outs see Page 22-09, Figure 2. The solid rivets can be set with a hand squeezer if a 1/2 [12.7 mm] tall set is used on the shop head side.

Final-Drill #34 the holes shown in Figure 2. Blind rivet the nose skin to nose rib holes as shown in Figure 2.

**FIGURE 2: RIVETING NOSE SKIN**

LP4-3 NOSE RIBS TO SPAR  
9 PLACES

**Step 3:** Cleco the Spar Assembly to the A-1001A-1L Nose Skin and to the A-1004-1R Nose Ribs and A-1015-1L Inboard Nose Rib as shown in Figure 1.

Blind rivet the nose ribs to the A-1003-1L Spar using the rivets called out in Figure 1.

**CAUTION:** When reaching down between the skins with the bucking bar be especially careful in this confined area that the bucking bar is not driven into the Top Skin Assembly while concentrating on the Bottom Skin Assembly.

**Step 4:** Remove the clecos from the top flange of the Spar Assembly and insert the Top Skin Assembly.

Cleco the Top Skin Assembly to the A-1003-1L Spar at every other hole. Clamp a straight board to the Top Skin Assembly near the trailing edge (to hold the top skin straight while riveting).

**Step 5:** Rivet the Top Skin Assembly to the spar. See Page 22-09, Figure 2 for all A-1001-1L Nose Skin rivets.

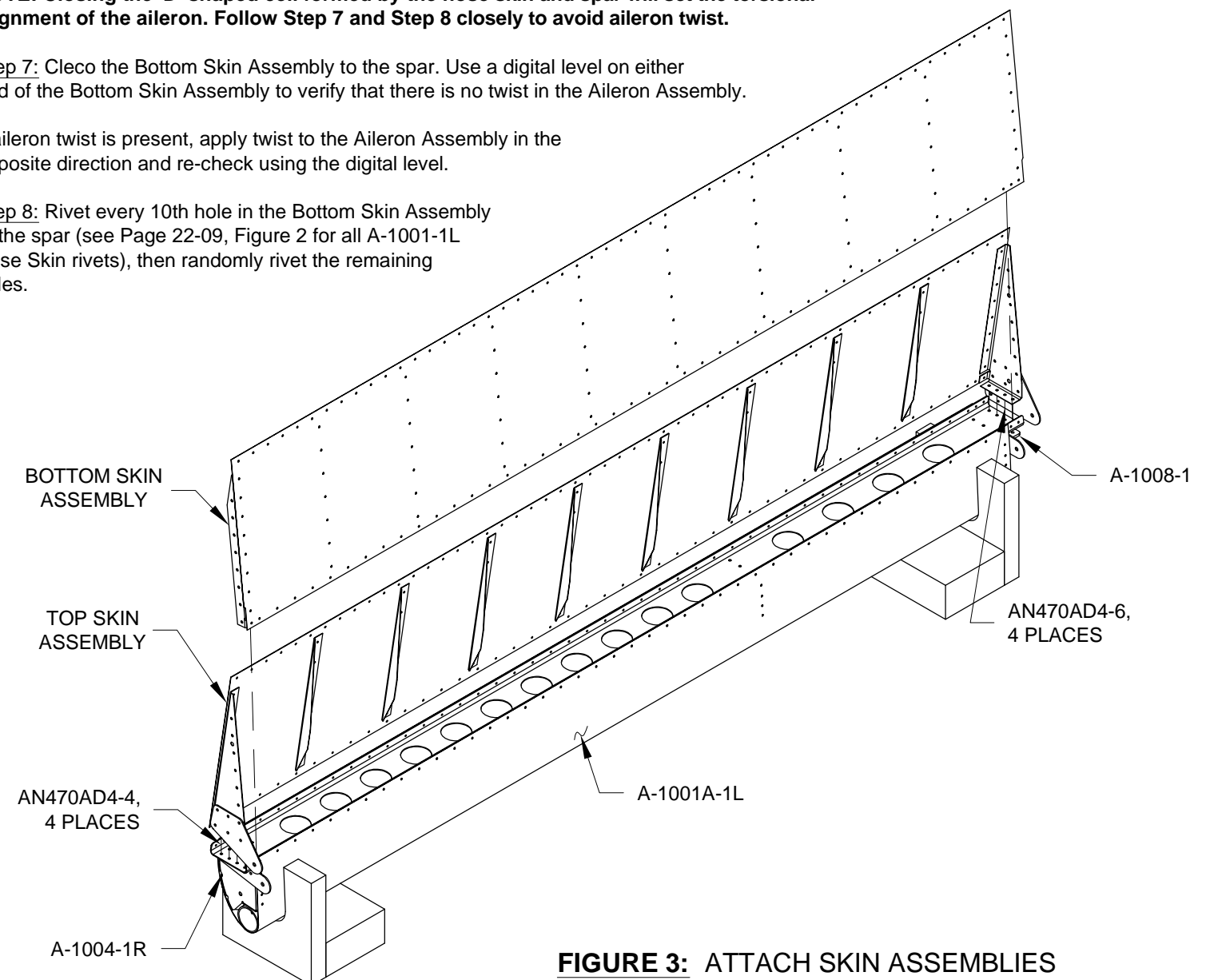
**Step 6:** Rivet the A-1005A-1L & -1R Main Ribs to the spar as shown in Figure 3.

**NOTE:** Closing the 'D' shaped cell formed by the nose skin and spar will set the torsional alignment of the aileron. Follow Step 7 and Step 8 closely to avoid aileron twist.

**Step 7:** Cleco the Bottom Skin Assembly to the spar. Use a digital level on either end of the Bottom Skin Assembly to verify that there is no twist in the Aileron Assembly.

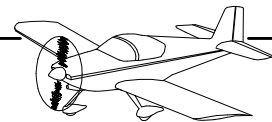
If aileron twist is present, apply twist to the Aileron Assembly in the opposite direction and re-check using the digital level.

**Step 8:** Rivet every 10th hole in the Bottom Skin Assembly to the spar (see Page 22-09, Figure 2 for all A-1001-1L Nose Skin rivets), then randomly rivet the remaining holes.



**FIGURE 3: ATTACH SKIN ASSEMBLIES**





Step 1: Cleco the A-1011-1 Trailing Edge into the Aileron as shown in Figure 1.

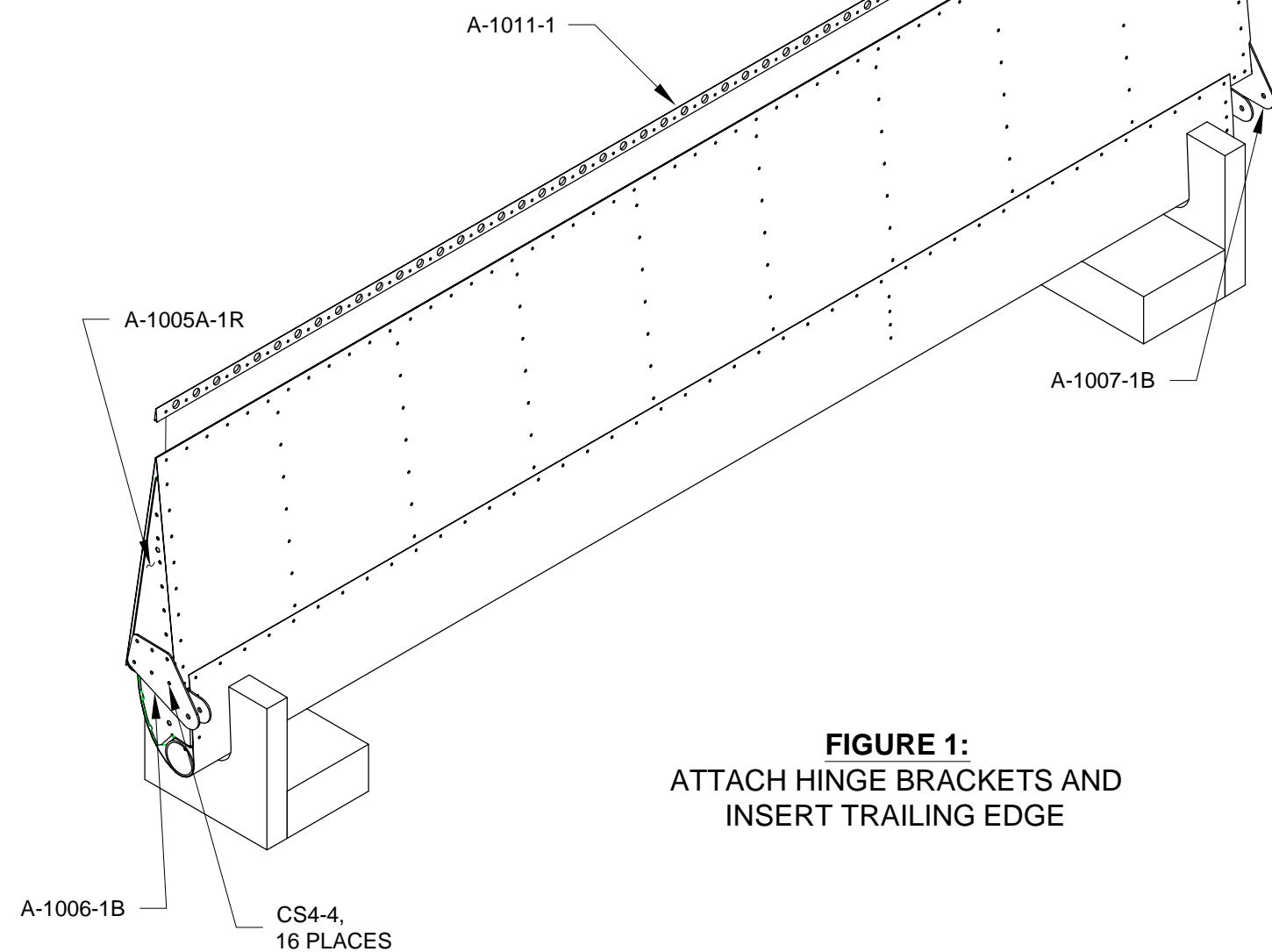
Step 2: Cleco the A-1005A-1L and A-1005B-1L Main Ribs together. Cleco the A-1005A-1R and A-1005B-1R Main Ribs together then rivet all main ribs as shown in Figure 1.

Step 3: Remove the Aileron from the cradle and lay it on its top with the trailing edge clecos hanging over the edge of the table as shown in Figure 3. Blind rivet the A-1009 Counterbalance to the A-1001A-1L Nose Skin (see Figure 2 for rivet call-outs). For a nicer finish use a small hammer to tap the top and bottom edges of the blind rivet heads down flush to the skin so that the rivet head follows the tight radius of the leading edge.

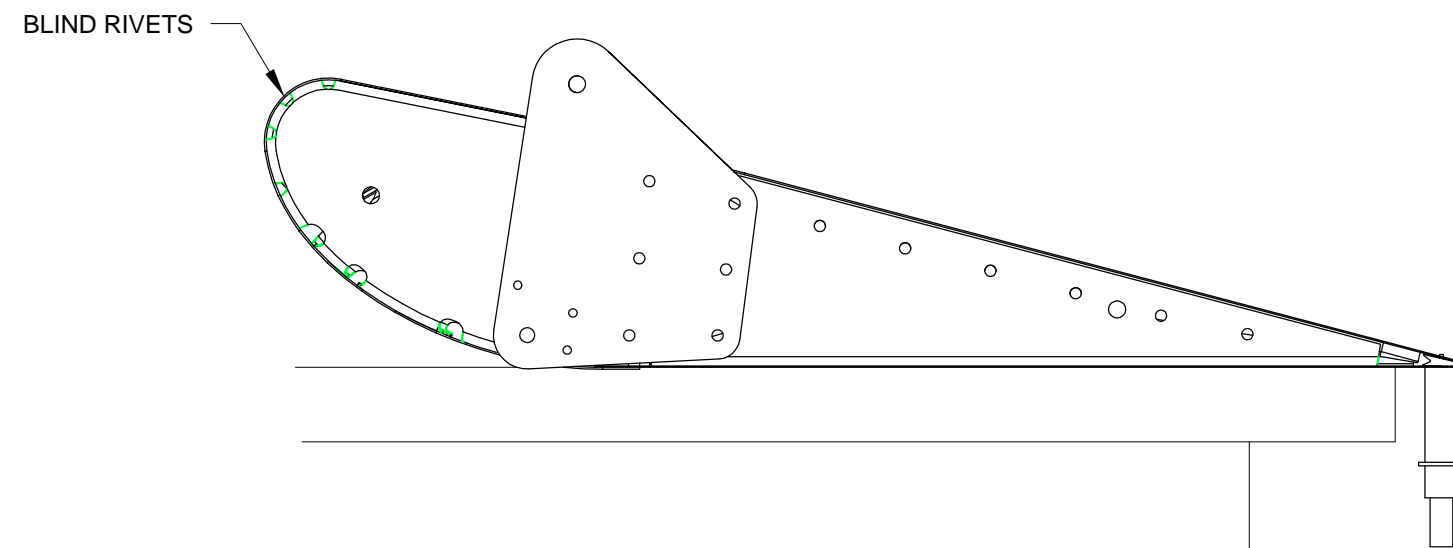
Step 4: Turn the Aileron over top side up.

Remove the A-1011 Trailing Edge as shown in Figure 1.

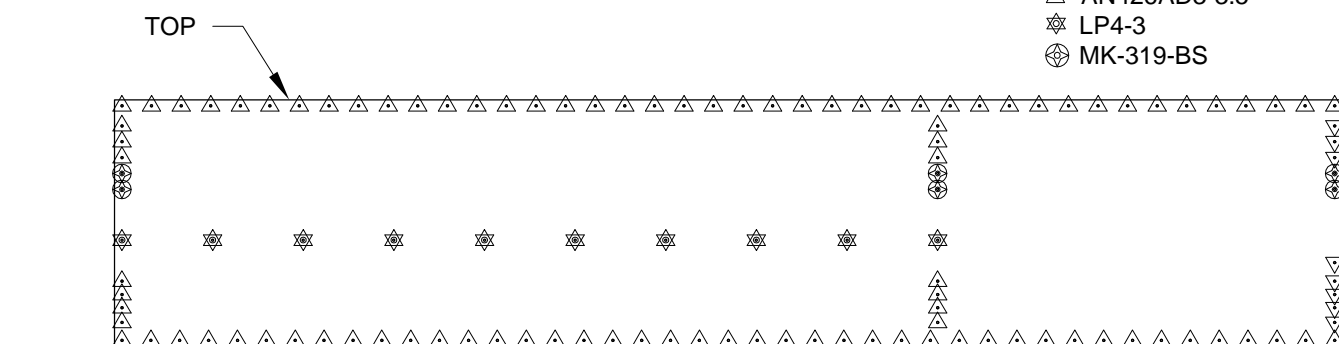
Complete the riveting of the aileron, refer to Section 5.8 for further instruction/technique. See Figure 4 for trailing edge rivet call-outs.



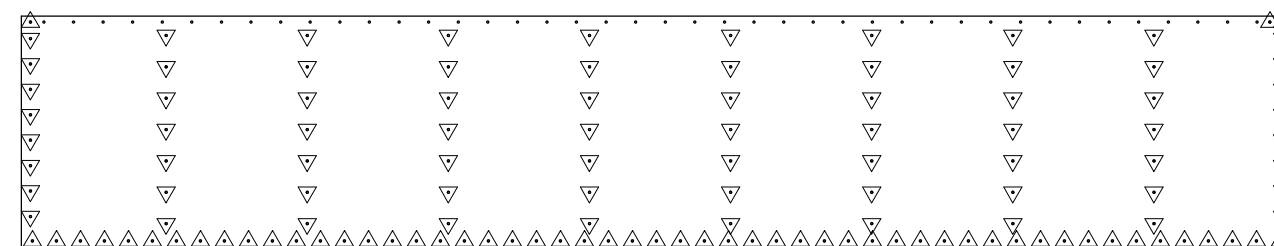
**FIGURE 1:**  
ATTACH HINGE BRACKETS AND  
INSERT TRAILING EDGE



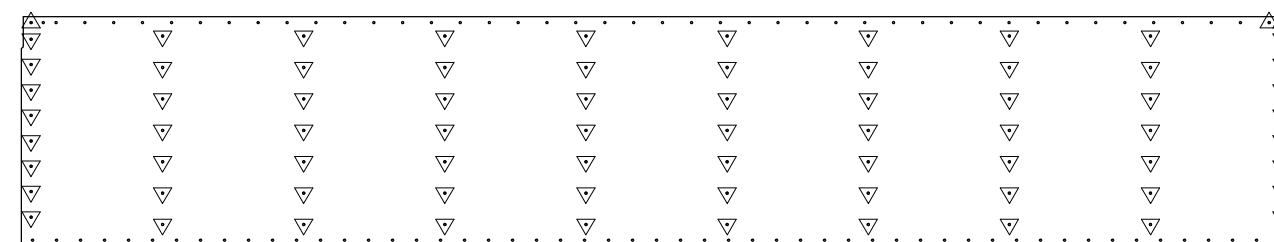
**FIGURE 3:** LEADING EDGE RIVETS



**FIGURE 2:** NOSE SKIN RIVETS



**FIGURE 4:** A-1001B-1 TOP SKIN RIVETS



**FIGURE 5:** A-1002-1 BOTTOM SKIN RIVETS



**THIS PAGE INTENTIONALLY LEFT BLANK**